

PENTAIR GOYEN MECAIR ECS/ECX SERIES

ECS CONTROL SYSTEM

DESCRIPTION

The ECS Control System is an intelligent controller developed to provide flexible solutions for economical filter life by minimising the costs associated with maintaining and operating modern dust filtration systems. The integrated dP transducer allows the controller to determine exactly when filters require cleaning. This feature ensures the filters are cleaned only when necessary, dramatically extending filter life and lowering emissions, while significantly reducing compressed air use.

The ECS base board has 12 solenoid outputs on board. The addition of expansion cards, matched to the AC or DC output of the controller, increases this number to 360 outputs. The ECS may be ordered as the control board only or in an enclosure.

FEATURES

- High-performance, cost-minimising controller.
- Expansion cards extend the control up to 360 solenoid outputs.
- Quick Pulse Technology.
- ECS supports parallel pilot valve connection.
- Low temperature operation -40°C (-40°F).
- Automatic pilot valve detection.
- Voltage-free coil error output and a visual indication on the display showing which pilot valve output has an error, enabling quick fault finding and debugging.
- Conforms to the requirements of CE, FCC, RCM, cURus, cULus, & ATEX.

TECHNICAL CHARACTERISTICS & PERFORMANCE

dP Support	0 to 4.5 kPa
Input Voltage	AC: 100–240 V $\pm 10\%$ @ 50/60 Hz
Output Voltage	AC: 100–240 V $\pm 10\%$ @ 50/60 Hz (same as input) DC: 24 V
Maximum Input Power	AC IN, AC OUT Model: 265 W AC IN, DC OUT Model: 75 W
Discrete Solenoid Outputs	12 outputs, expandable up to 360 via 12 output expansion cards
Enclosure	Polycarbonate, Stainless Steel or no enclosure
Humidity	20%–85% non-condensing
Maximum Altitude	2000 m (For higher, please consult manufacturer)
Protection Rating	Polycarbonate: NEMA 4/4X & IP65
Operating Temperature	<u>Non ATEX approved products:</u> -40°C to $+60^{\circ}\text{C}$ (-40°F to $+140^{\circ}\text{F}$) <u>Non ATEX approved ECS-ACDC12 with 3 DC pilot valves in parallel:</u> -20°C to $+60^{\circ}\text{C}$ (-4°F to $+140^{\circ}\text{F}$) <u>ATEX approved enclosure products:</u> -20°C to $+50^{\circ}\text{C}$ (-4°F to $+122^{\circ}\text{F}$)
ON & OFF Time	ON: 30 ms to 990 ms, OFF: 1 s to 999 s Note: Minimum OFF Time of 5 s is required in ATEX applications.
Inputs	Voltage Free: Fan Stop, Low Header, Demand/Continuous
Outputs	Voltage Free: Coil is Firing, Coil Alarm, High dP Analogue Output: 4–20 mA dP signal Controls up to 360 individual outputs. An ECS only AC output unit can have up to 10 pilot valves connected in parallel. An ECS only DC output unit can have up to 3 pilot valves connected in parallel. See Operating Temperature for more details.
Pollution Degree	For UL applications, product is suitable for pollution degree 2.

This device may be connected from a 3A rated MCB or ELCB protected branch circuit.

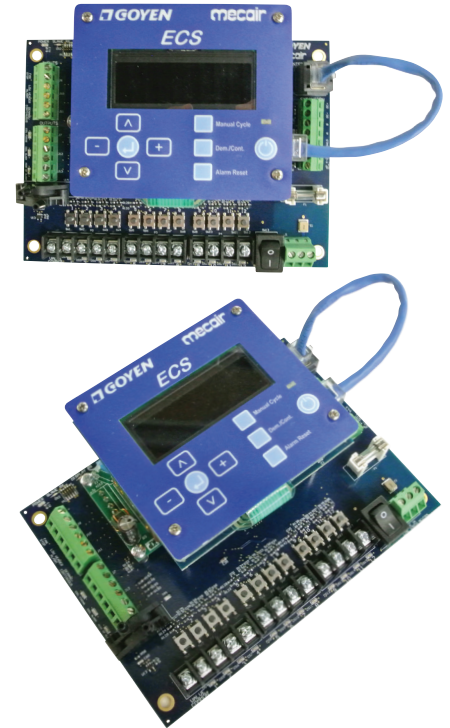

ORDER CODE - ECS

ECS - AC

Output Voltage
AC=AC V
(same as input)
DC=24 V DC

Outputs

12=12 outputs
24=24 outputs*
36=36 outputs*
48=48 outputs*
60=60 outputs*

* Uses larger polycarbonate enclosure

Enclosure type

PCA=ATEX & uULus approved polycarbonate enclosure
Blank=cURus approved non-enclosure product

ORDER CODE: ECX EXPANSION CARD

ECX - 12

Input Voltage
AC=AC V
DC=24 V DC

Output Voltage

AC=AC V
(same as input)
DC=DC V
(same as input)

ORDER CODE: ACCESSORIES

K-CPR-DIN (ECS DIN Mounting Kit)

ECS units inside a polycarbonate enclosure have ATEX approval:

CE **Ex** II 3 D Ex tc IIIC T59°C Dc IP65
Tamb: -20°C to +50°C

ECS units inside a polycarbonate enclosure have UL Listing:



Non-enclosure units have UL component recognition:



PCB BOARD DIMENSIONS - mm [inch]

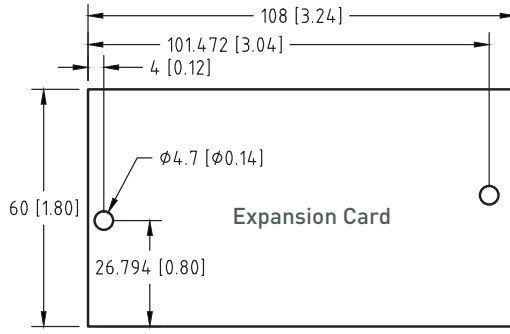
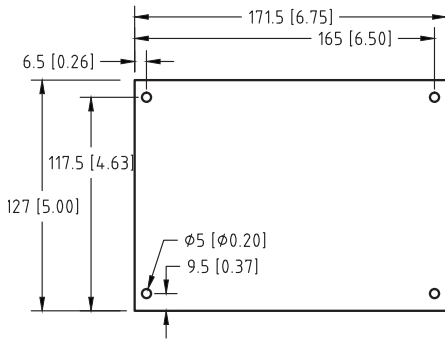

ENCLOSURE DIMENSIONS - mm [inch]

ECS Polycarbonate Enclosure

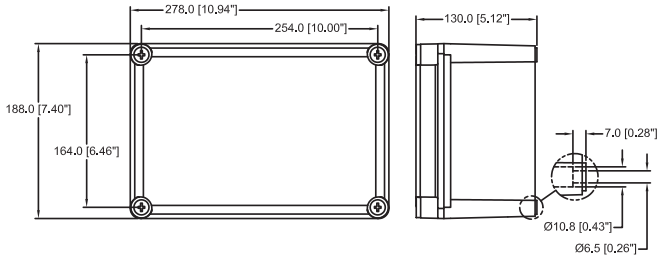

ECS/ECX Polycarbonate Enclosure

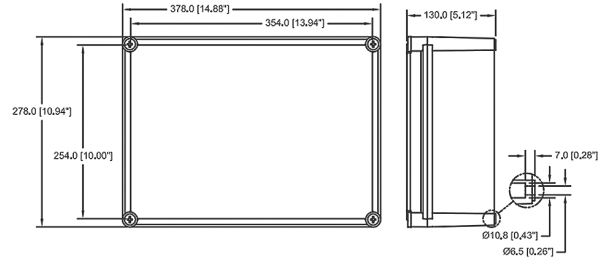

ECX INSIDE 3-12V PILOT ENCLOSURE

PILOT ENCLOSURE DIMENSIONS

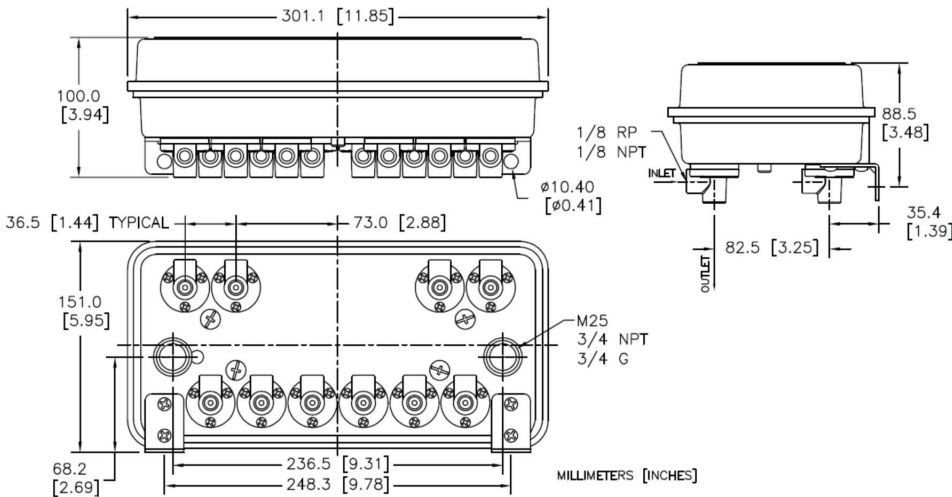

TECHNICAL CHARACTERISTICS & PERFORMANCE

Enclosure	Aluminium
Protection Rating	NEMA 4 & IP66
Operating Temperature	Non ATEX approved products: -40°C to +60°C [-40°F to +140°F] ATEX approved product: -20°C to +40°C [-4°F to +104°F]

INTERNAL WIRING

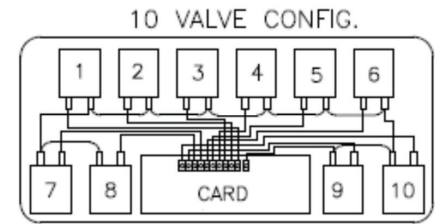

ORDERING CODES

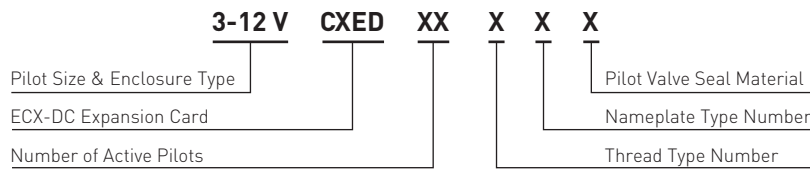

SEAL MATERIAL		
Material	Nitrile	Viton
Code	0	1

NAMEPLATE		
Nameplate Type	No Nameplate	Goyen
Code	0	1

NUMBER OF ACTIVE PILOTS											
Code	00	01	02	03	04	05	06	07	08	09	10

THREAD TYPE						
Conduit Thread	NPT	M	M	M	G	G
Pilot Thread	NPT	RP	RC	NPT	RP	RC
Code	0	1	N/A	3	4	N/A

ECX units inside the 3-12V pilot enclosure have ATEX approval:

CE **Ex** **II 3 D** **Ex tc IIIC T42°C Dc IP66** **Tamb: -20°C to +40°C**

ECX units inside a 3-12V enclosure and non-enclosure units have cULus approval:

